

SENSOR MUT2300

Electromagnetic flowmeter



EUROMAG
INTERNATIONAL
Measure > Sense > Innovate



The electromagnetic flowmeter designed for the toughest applications



DS401-3-ENG



Sensor MUT2300

The MUT2300 sensors represent the state of the art of Euromag International production for water cycle and process applications. The innovative inner part of the sensor that increase considerably the liquid flow rate and the reading accuracy of signal generated to the electrodes, enables an extremely wide range of measurement.

These performances allow to measure also low flow rates precisely and repeatable, even in difficult/problematic applications with solid parts.

This flanged sensor series bases its operation on the Faraday Principle, by which a conductor crossing a magnetic field generates an electrical potential perpendicular to the field itself. On the top and on the lower side of the stainless steel AISI 304 flow tube, two coils are installed; the magnetic field generated

by the electric current crossing the coils, induces in the electrodes a potential difference proportional to the flow rate.

With the aim of measuring such potential of very low values, the interior of the flow tube is electrically insulated, thus the process liquid is no longer in contact neither with the material of the flow tube nor with that of the flanges.

The converter used generates the current supplying the coils, acquires the electrodes potential difference, process the signal to calculate the flowrate and manages all the communications. The entire sensor has an IP68 protection degree suitable for a permanent immersion in water up to a depth of 1.5m.



Body and flanges

The flanges and the sensor external surface are acrylic painted. This treatment gives the sensor an excellent resistance to water and external agents even in permanent immersion or buried. The MUT2300 may be supplied in stainless steel, flanges included, or with a special paint ideal for application in C4 class environment (UNI EN ISO 12944-2).

Internal lining

The standard internal insulating lining is in Hard rubber (Ebonite) in compliance with WRAS, FDA and DM174 standards. The liquid temperature can reach 80°C. Thanks to its high resistance to scraping, the Ebonite is considered the best material for fluids containing scattered solids for applications of water treatment, residual water, potable water and irrigation.

Electrodes

The standard electrodes are in AISI316 and therefore this guarantees a wide compatibility with process fluids. If required, they may be supplied in Hastelloy C, Titanium, Tantalum and Platinum. A partially empty tube detection (fourth electrode) is installed and can be enabled or disabled through the software.

Coupling and connection to the sensor

MUT2300 sensors may be coupled with any Euromag converters. In the separate version the sensor is connected to the converter through a cable whose length depends on the liquid conductivity; the maximum length must not exceed 100 metres on the powered version and 30 metres on the battery version.

Neglectable pressure drop

The electromagnetic flowmeters do not have any moving internal parts, thus they have a very low pressure drop. The OIML R-49 permits a maximum pressure drop of 630 mbar at velocity of about 8 m/s. The MUT2300 flowmeters, thanks to its unique design, projected to accelerate the flow and amplify the signal to the electrodes, guarantees a pressure drop less than 100 mbar at velocity of 8 m/s. The pressure drop is always less than 10 mbar at velocities lower than 1 m/s.



MUT2300 - MC608A



MUT2300 - MC406 VERTICAL



MUT2300 - MC406 VERTICAL



MUT2300 - MC608A

Installation with no upstream and downstream distances

Standards reference

The Euromag magnetic meters are marked CE and are manufactured according to the following standards:

- 2014/35/EU - EN 61010-1:2013 (LVD)
- 2014/30/EU - EN 61326-1:2013 (EMC)
- OIML R49-1:2013
- European directive 2014/32/EU (MID)
- 2014/34/UE - IEC 60079 - 0, IEC 60079 - 18 (ATEX - IECEx) Separate version
- EN ISO 15609-1 and EN ISO 15614-1
- UNI EN ISO 12944-2, painting for C4 class environments (on request)
- Ebonite conform to the norms WRAS, FDA e DM174

Applications

- Measure of potable or reflow water
- Distribution, municipal water
- Industrial waste water
- Over night applications with very low flow rate
- Industrial process liquids, muds and concretes
- Installation in small places without straight distances
- Leakage detection
- Fiscal measures, irrigation

Advantages

No moving parts ■ No parts inside of the flowmeter ■ No obstruction on the flow tube ■ Very low pressure loss (below 1 m/s is irrelevant) ■ Long lasting stability and precision, no filter needed, zero maintenance ■ No periodic cleaning ■ Accurate measure at high flow rate (firefighting systems) and at low flow rates (overnight flow rates) ■ Extremely sturdy structure, a dedicated robot welds all the parts, internal parts protected by a bi-component resin in order to increase protection from external agents ■ Ideal for pit installations even for permanent immersion in water or buried installations ■ Bi-directional measure

Technical features MUT2300

Flow tube material	AISI 304, AISI 316 (optional)									
Flanges material	Carbon steel (S235JR - 1.0037), AISI 304 optional, AISI 316 optional									
Available electrodes	AISI316 (standard), Hastelloy C, Hastelloy B, Titanium, Tantalum, Platinum									
Internal lining	Ebonite									
Liquid temperature	-40°C / + 80°C									
Available diameters	mm	50	65	80	100	125	150	200	250	300
	inches	2"	2½"	3"	4"	5"	6"	8"	10"	12"
Standard flanged connections	EN1092-1 PN 16, ANSI 150									
Flanged connections on request	AS 2129 (Table D, E, F), AS 4087 (PN 16, 21), KS10K, others on request									
Standard operation pressure	21 bar									
Pressure drop class	DN≤80 ΔP10 (< 0,10 bar)					DN≥100 ΔP16 (< 0,16 bar)				
Installation requirements/conditions	U0-D0									
Protection Degree	IP68 permanent submersion at 1,5 m (EN 60529)									
Convertes compatibility	MC608A/B/R/P, MC406									
Electrical connections	Cableglands M20 x 1.5 + terminal box + sealing resin									

Calibration and maximum error

Each sensor is calibrated on an hydraulic test rig equipped with a ISO17025 traceable weighing system. The accuracy is equal to 0,2% ± 2mm/s. The repeatability of the measure is about 0,1%. Bi-directional measure. On request the sensors can be supplied certified MID OIML R49 (if coupled to MC406M converters) for custody transfer.

Maximum Permissible Error is within the limits indicated in the following graph:

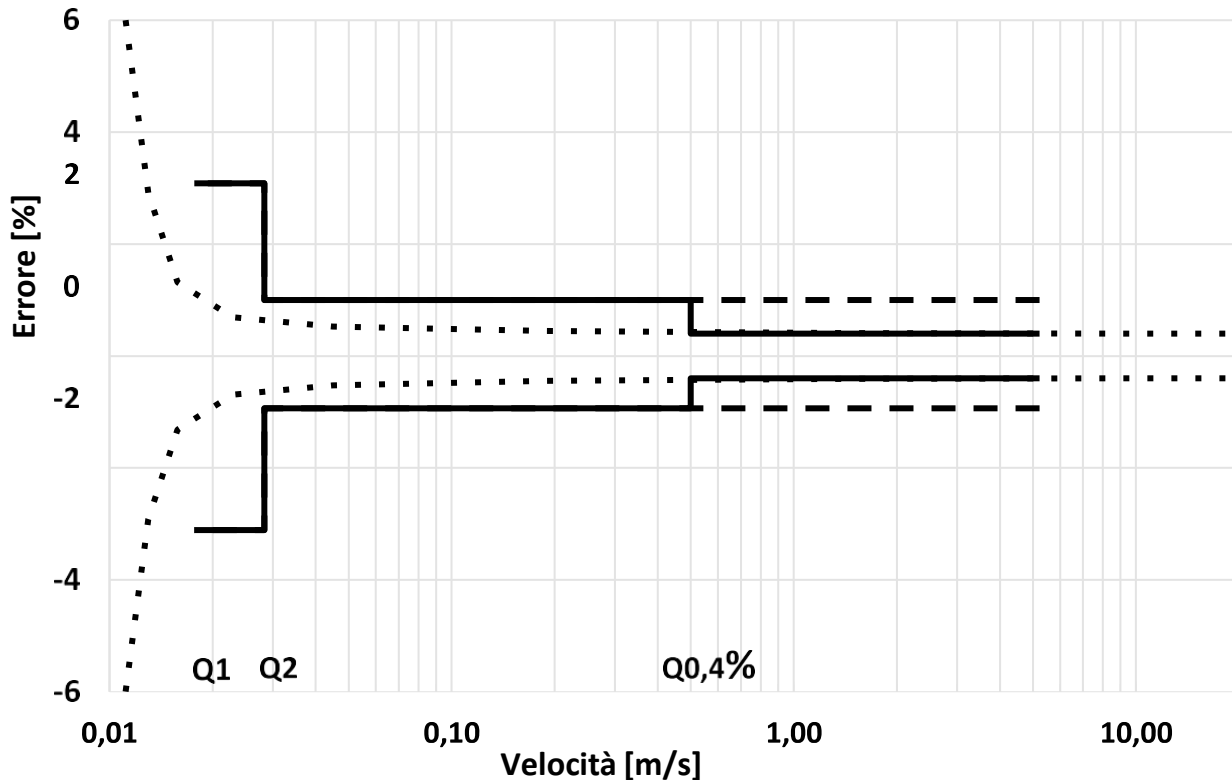

Flow rates chart

Sensor diameter	Flow [m3/h]					Ratio Q3/Q1
	Min Q1	Trans. Q2	Q0,4%	Perm. Q3	Overl. Q4	
DN50 - 2"	0,125	0,20	3,50	25,00	31,25	200
DN65 - 2"1/2	0,20	0,32	6,00	40,00	50,00	200
DN80 - 3"	0,315	0,50	9,00	63,00	78,75	200
DN100 - 4"	0,50	0,80	14,00	100,00	125,00	200
DN125 - 5"	0,80	1,28	22,00	160,00	200,00	200
DN150 - 6"	1,25	2,00	32,00	250,00	312,50	200
DN200 - 8"	3,15	5,04	57,00	630,00	787,50	200
DN250 - 10"	5,00	8,00	90,00	1000,00	1250,00	200
DN300 - 12"	8,00	12,50	128,00	1000,00	1250,00	125

MUT2300 - MC406 HORIZONTAL

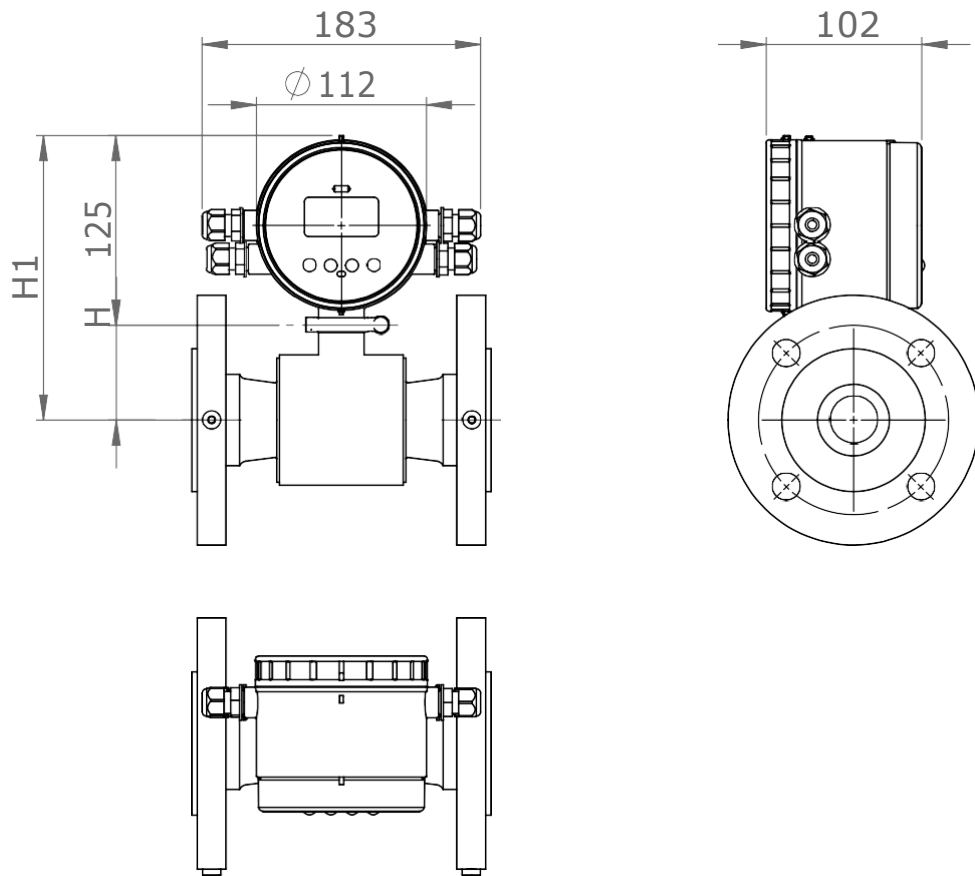

MC406 HORIZONTAL

DN	H	H1
50 - (2")	62	187
65 - (2" 1/2)	62	187
80 - (3")	71	196
100 - (4")	79	204
125 - (5")	106	231
150 - (6")	101	226
200 - (8")	147	272
250 - (10")	176	301
300 - (12")	207	332

MUT2300 - MC406 VERTICAL

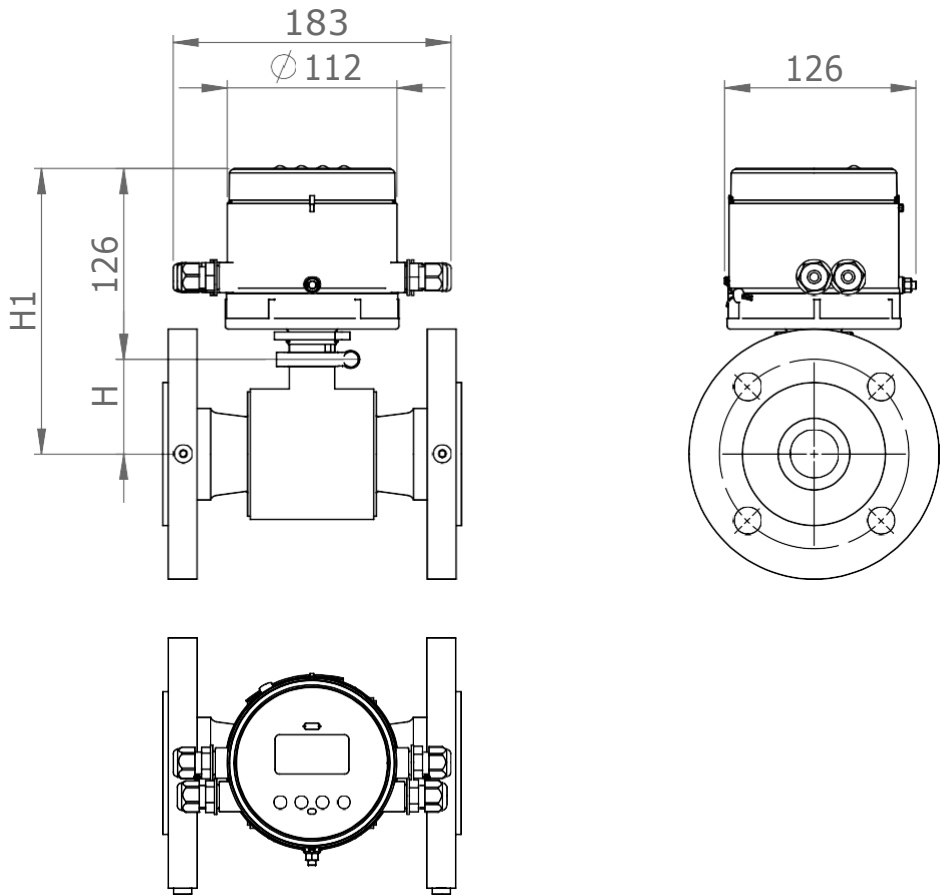

MC406 VERTICAL

DN	H	H1
50 - (2")	62	188
65 - (2" 1/2)	62	188
80 - (3")	71	197
100 - (4")	79	205
125 - (5")	106	232
150 - (6")	101	227
200 - (8")	147	273
250 - (10")	176	302
300 - (12")	207	333

MUT2300 - MC608 A/B/R

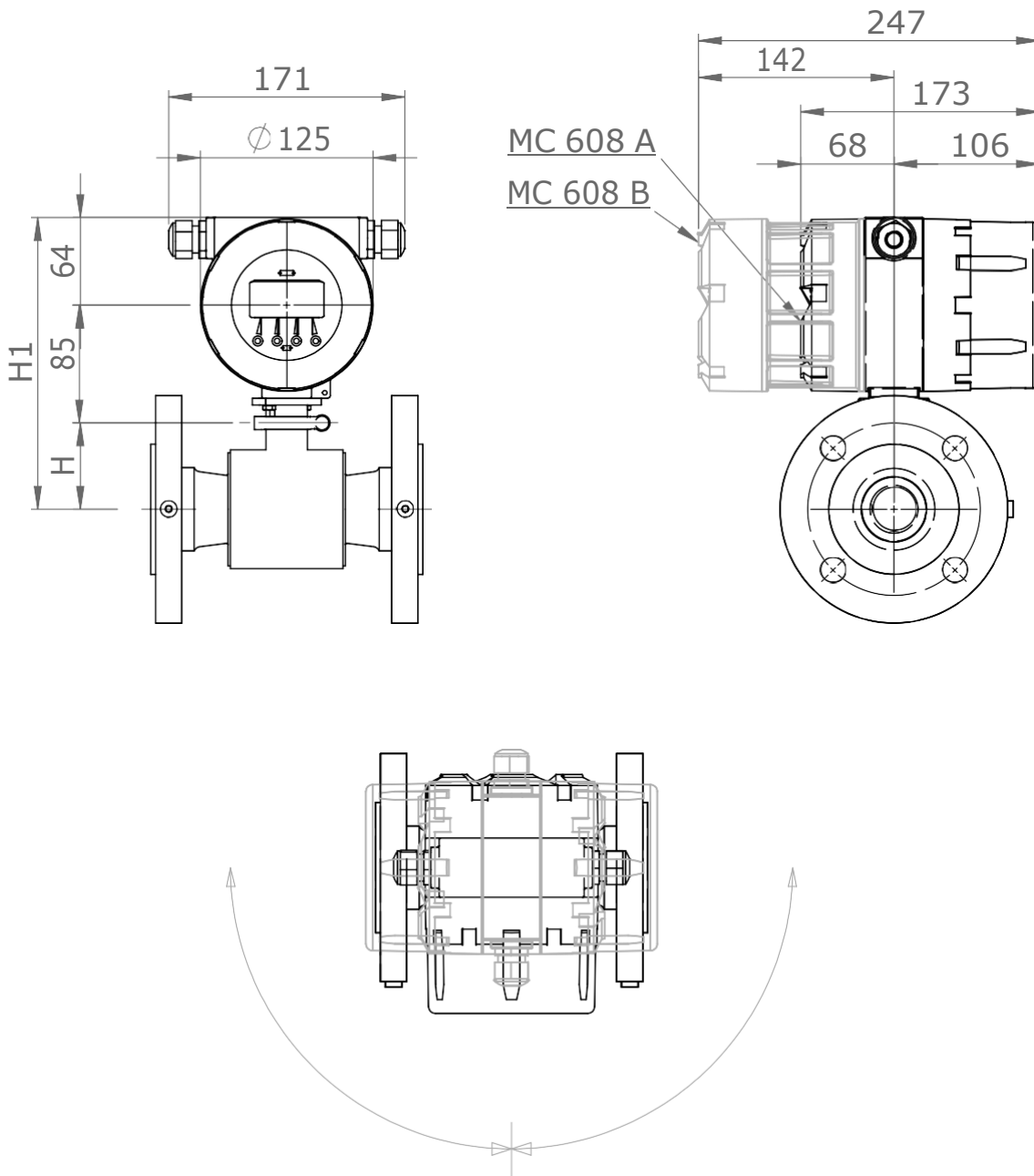

MC608 A/B/R

DN	H	H1
50 - (2")	62	211
65 - (2" 1/2)	62	211
80 - (3")	71	220
100 - (4")	79	228
125 - (5")	106	255
150 - (6")	101	250
200 - (8")	147	296
250 - (10")	176	325
300 - (12")	207	356

MUT2300 - SEPARATE

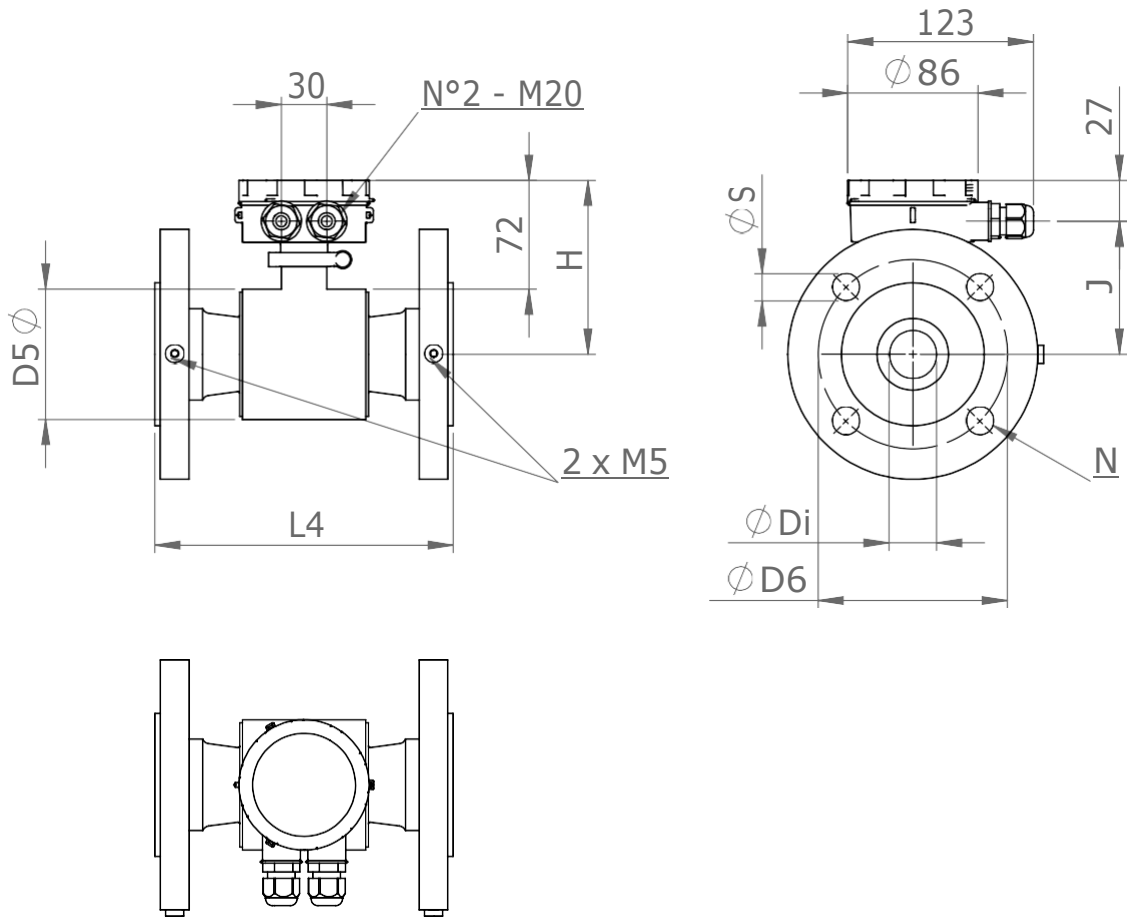

MUT2300 - EN 1092 / PN 16

DN	D5	L4	J	Di	D6	N	S	H
50	85	200 (+0/-3)	87,35	30,4	125	4	18	114,5
65	85	200 (+0/-3)	87,35	34,3	145	8	18	114,5
80	103	200 (+0/-3)	96,35	46,3	160	8	18	123,5
100	118	250 (+0/-3)	103,85	62,1	180	8	18	131
125	172	250 (+0/-3)	130,85	74,9	210	8	18	158
150	163	300 (+0/-3)	126,35	100	240	8	22	153,5
200	255	350 (+0/-3)	172,35	154,3	295	12	22	199,5
250	312	450 (+0/-5)	200,85	205	355	12	26	228
300	375	500 (+0/-5)	232,35	259	410	12	26	259,5

MUT2300 - ANSI 150

DN	D5	L4	J	Di	D6	N	S	H
2" - (DN 50)	85	200 (+0/-3)	87,35	30,4	120,6	4	19,0	114,5
2" 1/2 - (DN 65)	85	200 (+0/-3)	87,35	34,3	139,7	4	19,0	114,5
3" - (DN 80)	103	200 (+0/-3)	96,35	46,3	152,4	4	19,0	123,5
4" - (DN 100)	118	250 (+0/-3)	103,85	62,1	190,5	8	19,0	131
5" - (DN 125)	172	250 (+0/-3)	130,85	74,9	215,9	8	22,2	158
6" - (DN 150)	163	300 (+0/-3)	126,35	100	241,3	8	22,2	153,5
8" - (DN 200)	255	350 (+0/-3)	172,35	154,3	298,4	8	22,2	199,5
10" - (DN 250)	312	450 (+0/-5)	200,85	205	361,9	12	25,4	228
12" - (DN 300)	375	500 (+0/-5)	232,35	259	431,8	12	25,5	259,5

MUT2300 - AS 2129 / Table D

DN	D5	L4	J	Di	D6	N	S	H
50	85	200 (+0/-3)	87,35	30,4	114	4	18	114,5
65	85	200 (+0/-3)	87,35	34,3	127	4	18	114,5
80	103	200 (+0/-3)	96,35	46,3	146	4	18	123,5
100	118	250 (+0/-3)	103,85	62,1	178	4	18	131
125	172	250 (+0/-3)	130,85	74,9	210	8	18	158
150	163	300 (+0/-3)	126,35	100	235	8	18	153,5
200	255	350 (+0/-3)	172,35	154,3	292	8	18	199,5
250	312	450 (+0/-5)	200,85	205	356	8	22	228
300	375	500 (+0/-5)	232,35	259	406	12	22	259,5

MUT2300 - AS 2129 / Table E

DN	D5	L4	J	Di	D6	N	S	H
50	85	200 (+0/-3)	87,35	30,4	114	4	18	114,5
65	85	200 (+0/-3)	87,35	34,3	127	4	18	114,5
80	103	200 (+0/-3)	96,35	46,3	146	8	18	123,5
100	118	250 (+0/-3)	103,85	62,1	178	8	18	131
125	172	250 (+0/-3)	130,85	74,9	210	8	18	158
150	163	300 (+0/-3)	126,35	100	235	8	22	153,5
200	255	350 (+0/-3)	172,35	154,3	292	8	22	199,5
250	312	450 (+0/-5)	200,85	205	356	12	22	228
300	375	500 (+0/-5)	232,35	259	406	12	26	259,5

MUT2300 - AS 4087 / PN 16

DN	D5	L4	J	Di	D6	N	S	H
50	85	200 (+0/-3)	87,35	30,4	114	4	18	114,5
65	85	200 (+0/-3)	87,35	34,3	127	4	18	114,5
80	103	200 (+0/-3)	96,35	46,3	146	8	18	123,5
100	118	250 (+0/-3)	103,85	62,1	178	4	18	131
125	172	250 (+0/-3)	130,85	74,9	210	8	18	158
150	163	300 (+0/-3)	126,35	100	235	8	18	153,5
200	255	350 (+0/-3)	172,35	154,3	292	8	18	199,5
250	312	450 (+0/-5)	200,85	205	356	8	22	228
300	375	500 (+0/-5)	232,35	259	406	12	22	259,5

Zero upstream and downstream distances



